

Spare Parts List
Ersatzteilliste
Liste de pièces détachées
Lista de piezas de repuesto

2014-02

PE-254.4

DOLMAR



A member of the *Makita* Group

PE-254.4 (D, GB, F, E)

Zubehör
 Accessories
 Accessoires
 Accesorios

- A01
- A03
- A04
- A06

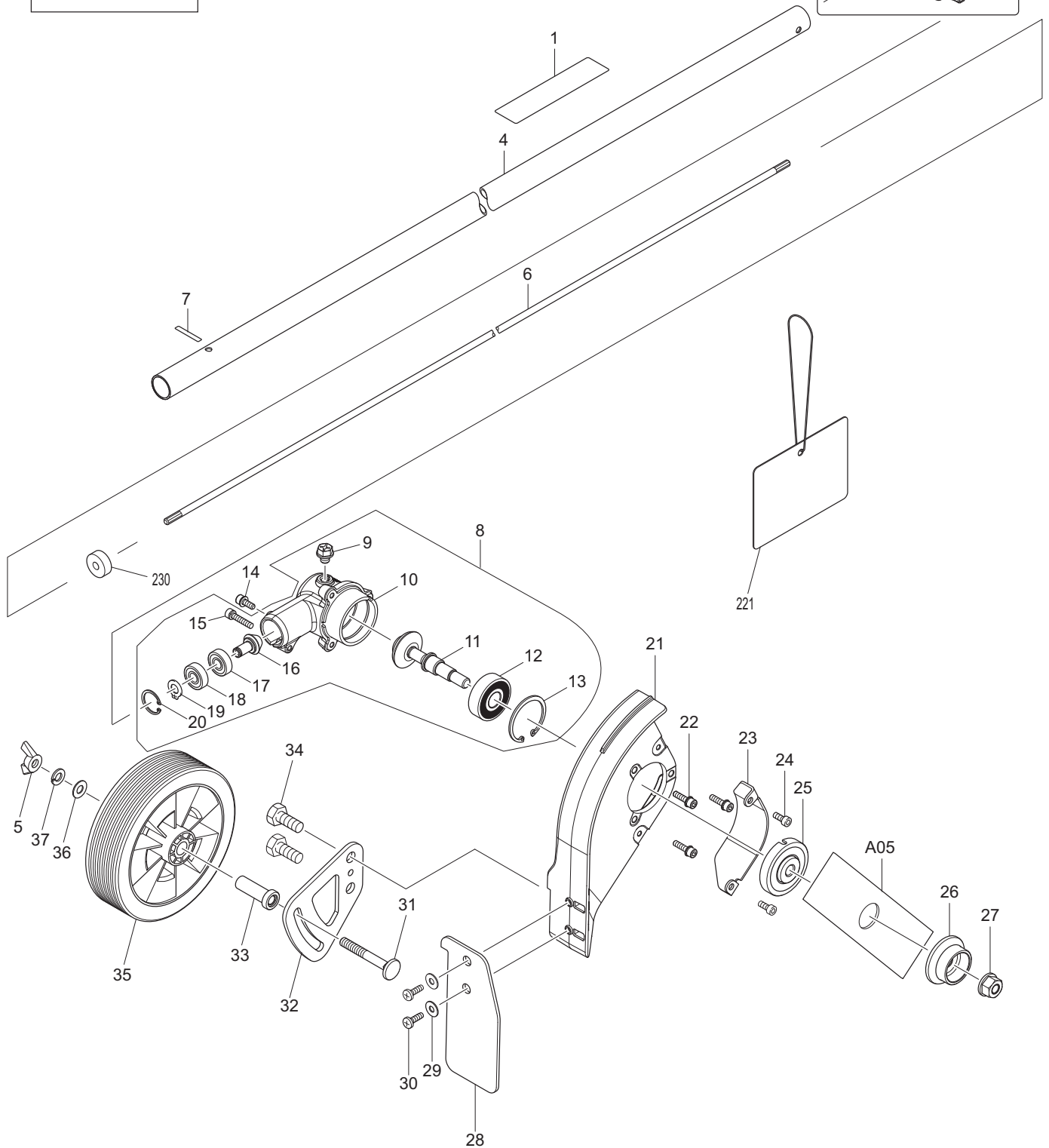
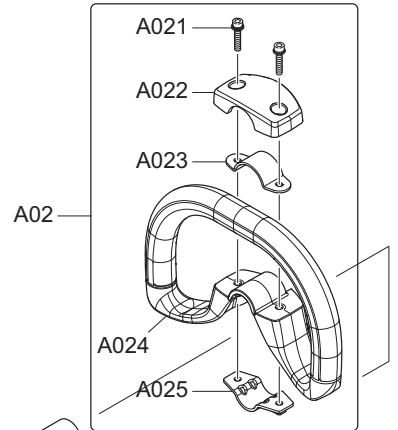

PE-254.4

1

Rasenkantenschneider, Zubehör
Edger, accessory
Dresse-bordures, accessoires
Rebordeadora, accesorios

DOLMAR
A member of the *Makita* Group

Seite / Page	Pos.	Teil-Nr. Part No. No. de pièce No. de pieza	Hinweise Notes Renseign. Nota	Bezeichnung	Spezifikation Specification	Description	Désignation	Denominación
1	1	660 893 388		SCHILD	DOLMAR LOGO	LABEL	PLAQUE	CALCOMANIA
1	4	660 142 512		SCHAFTROHR KPL.		SHAFT PIPE COMPLETE	TUBE PRINCIPAL CPL.	TUBO PRINCIPAL CPL.
1	4	367 803 034		SICHERHEITSAUFKL EBER		CAUTION LABEL	PLAQUE	CALCOMANIA
1	4	367 808 723		SICHERHEITSAUFKL EBER		CAUTION LABEL	PLAQUE	CALCOMANIA
1	5	660 934 401		FLÜGELMUTTER	M8	WING NUT	ÉCROU À OREILLES	TUERCA DE MARIPOSA
1	6	367 324 893		WELLE		SHAFT	ARBRE	ÁRBOL
1	7			SCHILD	SERIAL NO.	LABEL	PLAQUE	CALCOMANIA
1	8	660 126 414		GETRIEBEGEHÄUSE KPL.		GEAR CASE ASS'Y	CARTER D'ENGRENAGES CPL.	CAJA DE ENGRANAJES CPL.
1	9	367 265 590		SCHRAUBE	M8X10	+HEX.BOLT WITH R	VIS HEXAGONAL	TORNILLO HEXAGONAL
1	10	660 319 102		GETRIEBEGEHÄUSE		GEAR CASE	CARTER D'ENGRENAGES	CAJA DE ENGRANAJES
1	11	660 126 415		WINKELANTRIEB		CUTTER SHAFT ASS'Y	ENGRENAGE	ENGRANAJE
1	12	660 211 231		KUGELLAGER	6302DDW	BALL BEARING	ROULEMENT À BILLES	RODAMIENTO DE BOLAS
1	13	660 962 201		SICHERUNGSRING	(INT) R-42	RETAINING RING	CIRCLIP	ANILLO SEGURIDAD
1	14	367 922 218		SCHRAUBE	M5X14	H.S.H.BOLT WITH WR	VIS	TORNILLO
1	15	367 922 241		SCHRAUBE	M5X25	HEX. SOCKET HEAD BOLT	VIS HEXAGONAL	TORNILLO HEXAGONAL
1	16	660 227 629		SPIRALKEGELRAD	14	SPIRAL BEVEL GEAR	ROUE CONIQUE	ENGRANAJE CÓNICO
1	17	367 210 049		KUGELLAGER	609ZZ	BALL BEARING	ROULEMENT À BILLES	RODAMIENTO DE BOLAS
1	18	367 210 049		KUGELLAGER	609ZZ	BALL BEARING	ROULEMENT À BILLES	RODAMIENTO DE BOLAS
1	19	367 961 005		SICHERUNGSRING	S-9	RETAINING RING	CIRCLIP	ANILLO SEGURIDAD
1	20	367 962 103		SICHERUNGSRING	R-24	RETAINING RING	CIRCLIP	ANILLO SEGURIDAD
1	21	660 319 111		SCHUTZHAUBE		PROTECTOR	CAPOT DE PROTECTION	CUBIERTA PROTECTORA
1	22	320 922 233		SCHRAUBE	M5X20	HEX SOCKET HEAD BOLT	VIS	TORNILLO
1	23	660 346 759		SCHUTZ		GUARD PLATE	PROTECTION	PROTECCIÓN
1	24	660 266 874		INNEN-6KT-SCHRAU BE	M5x14	H.S.H. BOLT	VIS	TORNILLO
1	25	660 326 382		AUFNAHMESCHEIBE		RECEIVE WASHER	DISQUE DE SUPPORT	DISCO DE SUJECIÓN
1	26	660 326 381		DRUCKSCHEIBE		CLAMP WASHER	DISQUE DE PRESSION	DISCO DE PRESION
1	27	367 264 025		SECHSKANTMUTTER	M10-17	HEX NUT	ECROU HEXAGONAL	TUERCA HEXAGONAL
1	28	660 424 615		ABWEISER		DEFLECTOR	DEFLECTEUR	DEFLECTOR
1	29	660 253 804		FLACHSCHEIBE	6	FLAT WASHER	RONDELLE PLATE	ARANDELA
1	30	660 266 027		SCHNEIDSCHRAUBE	CT5X16	TAPPING SCREW	VIS TARAUDEUSE	TORNILLO DE ROSCA CORTANTE
1	31	660 266 876		SCHRAUBE MIT VIERKANTANSATZ	M8X62	C.H. SQUARE NECK BOLT	VIS	TORNILLO
1	32	660 346 758		PLATTE		PLATE	PLAQUE	PLACA
1	33	660 257 821		BUCHSE	8	SLEEVE	DOUILLE	CASQUILLO
1	34	660 921 542		6KT-SCHRAUBE	M10X25	HEX. BOLT	VIS	TORNILLO
1	35	660 454 843		RAD		WHEEL	ROUE	RUEDA
1	36	660 941 201		SCHEIBE	8	WASHER	RONDELLE	ARANDELA
1	37	320 942 201		FEDERSCHEIBE		SPRING WASHER	RONDELLE A RESSORT	ARANDELA ELASTICO
1	230	367 443 170		FILZRING		FELT	BAGUE EN FEUTRE	ANILLO DE FIELTRO
1	A01	980 008 123		MOTORÖL	SAE 10W-40, 80ml DOLMAR	OIL SET	BIDON, HUILE	BOTELLA, ACEITE
1	A02	660 195 626		HANDGRIFF KPL.		LOOP HANDLE SET	POIGNÉE CPL.	MANGO CPL.

Zubehör
 Accessories
 Accessoires
 Accesorios

- A01
- A03
- A04
- A06

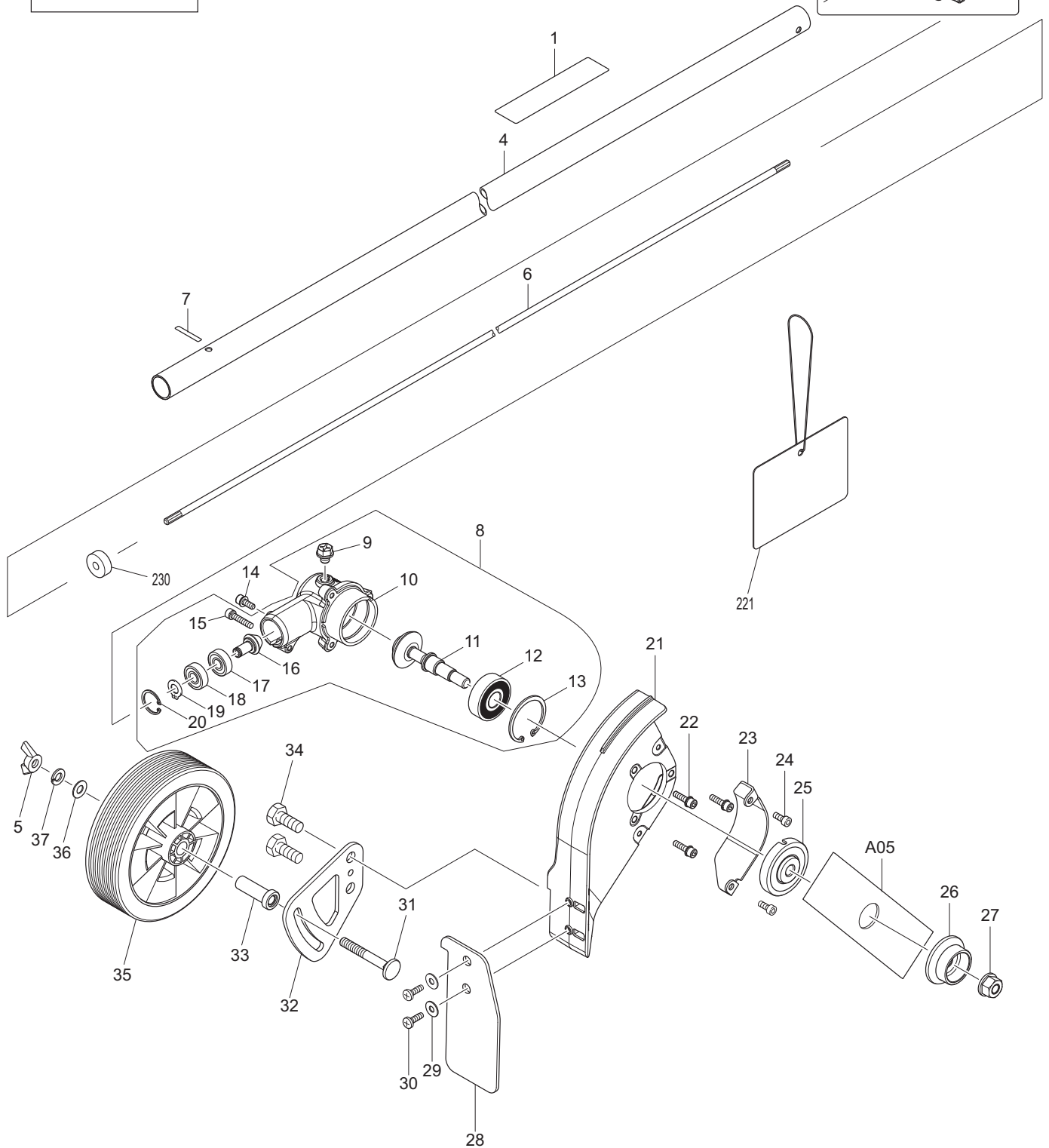
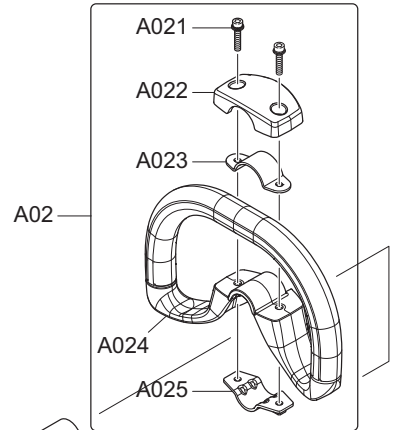

PE-254.4

1

Rasenkantenschneider, Zubehör
Edger, accessory
Dresse-bordures, accessoires
Rebordeadora, accesorios

DOLMAR
A member of the *Makita* Group

Seite / Page	Pos.	PE-254.4	Teil-Nr. Part No. No. de pièce No. de pieza	Hinweise Notes Renseign. Nota	Bezeichnung	Spezifikation Specification	Description	Désignation	Denominación
1	A02 1	2	660 922 243		6KT-SCHRAUBE	M5X25	HEX. SOCKET HEAD BOLT	VIS	TORNILLO
1	A02 2	1	660 452 843		ABDECKUNG	B	COVER	COUVERCLE	CUBIERTA
1	A02 3	1	381 346 468		KLEMMSCHELLE	33	CLAMP	COLLIER DE SERRAGE	ABRAZADERA DE SUJECIÓN
1	A02 4	1	660 452 841		HANDGRIFF		LOOP HANDLE	POIGNÉE	MANGO
1	A02 5	1	381 346 467		KLEMMSCHELLE	24	CLAMP	COLLIER DE SERRAGE	ABRAZADERA DE SUJECIÓN
1	A03	1	367 783 013		KOMBISCHLÜSSEL	SW 16/17	BOX WRENCH	CLÉ COMBINÉE	LLAVE DE BUJIA
1	A04	1	374 832 020		6KT-STIFTSCHLÜSSEL	4	HEX. WRENCH	CLÉ MÂLE COUDÉE	LLAVE HEXAGONAL
1	A05	1	374 196 784		MESSER	PE-254.4, PE-CS	BLADE	LAME	CUCHILLA
1	A06	1	660 831 315		ZUBEHÖRTASCHE	DOLMAR	ACCESSORY BAG	POCHETTE D'ACCESSOIRES	BOLSO DE ACCESORIOS

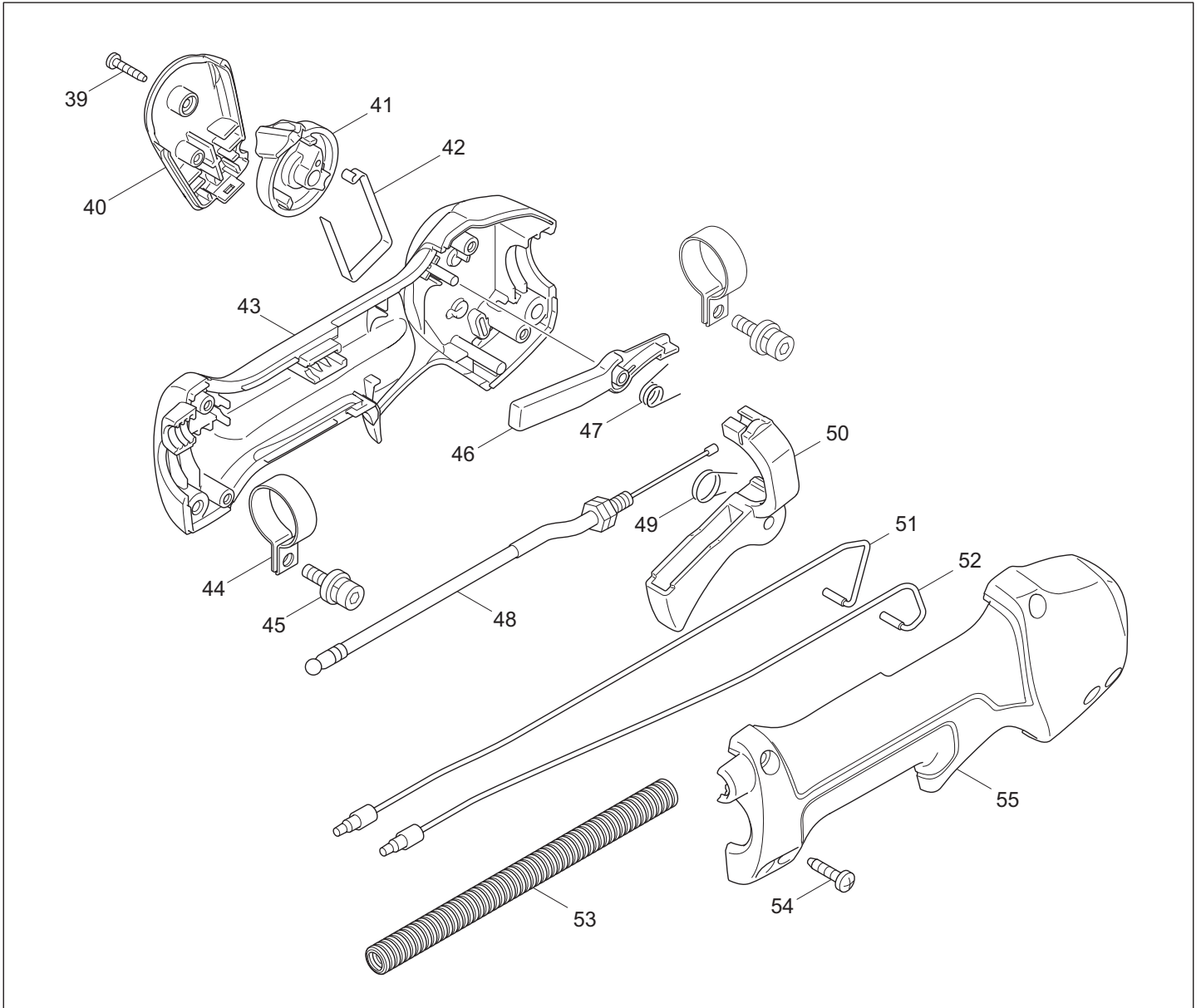

Seite / Page	Pos.	PE-254.4	Teil-Nr. Part No. No. de pièce No. de pieza	Hinweise Notes Renseign. Nota	Bezeichnung	Spezifikation Specification	Description	Désignation	Denominación
2	38	1	660 126 488		BEDIENUNGSHANDGRIF FF KPL.		CONTROL LEVER ASS'Y	LEVIER DE RÉGLAGE, CPL.	BOTÓN DE MANDO, CPL.
2	39	1	367 266 130		GEWINDESCHNEIDSC HRAUBE	3x16	TAPPING SCREW BIND TP	VIS TARAUDEUSE	TORNILLO DE ROSCA CORTANTE
2	40	1	367 451 595		SCHALTERDECKEL		SWITCH COVER	COUVERCLE COMMUTATEUR	CUBIERTA CONMUTADOR
2	41	1	367 451 594		SCHALTHEBEL		SWITCH LEVER	LEVIER DU COUPE CIRCUIT	MANO INTERRUPTOR
2	42	1	367 232 251		BLATTFEDER		LEAF SPRING	LAME RESSORT	RESORTE DE LA LÁMINA
2	43	1	367 188 832		GRIFFSCHALEN, SATZ	INC. 43, 55	LEVER CASE, SET	POIGNÉE, JEU	MANGO, JUEGO
2	44	2	367 346 248		KLEMMSCHELLE	24	CLAMP	COLLIER DE SERRAGE	ABRAZADERA DE SUJECIÓN
2	45	2	367 922 218		SCHRAUBE	M5X14	H.S.H.BOLT WITH WR	VIS	TORNILLO
2	46	1	367 451 593		RASTHEBEL		LOCK LEVER	LEVIER DE VERROUILLAGE	PALANCA TRINCADA
2	47	1	367 233 541		TORSIONSFEDER	7	TORSION SPRING	RESSORT À TORSION	MUELLE DE TORSIÓN
2	48	1	367 168 571		BOWDENZUG		CONTROL CABLE	CÂBLE BOWDEN	TRACCIÓN BOWDEN
2	49	1	367 233 540		TORSIONSFEDER	11	TORSION SPRING	RESSORT À TORSION	MUELLE DE TORSIÓN
2	50	1	660 455 313		GASHEBEL		THROTTLE LEVER	LEVIER D' ACCÉLÉRATION	PALANCA DEL ACELERADOR
2	51	1	367 638 714		KABEL		LEAD UNIT	CÂBLE	CABLE
2	52	1	367 638 713		KABEL		LEAD UNIT	CÂBLE	CABLE
2	53	1	367 452 071		FALTENSCHLAUCH		CORRUGATED TUBE	TUBE À SOUFFLETS	TUBO ONDULADO
2	54	4	660 266 326		SCHNEIDSCHRAUBE	4X18	SCREW	VIS	TORNILLO
2	55	1	367 188 832		GRIFFSCHALEN, SATZ	INC. 43, 55	LEVER CASE, SET	POIGNÉE, JEU	MANGO, JUEGO

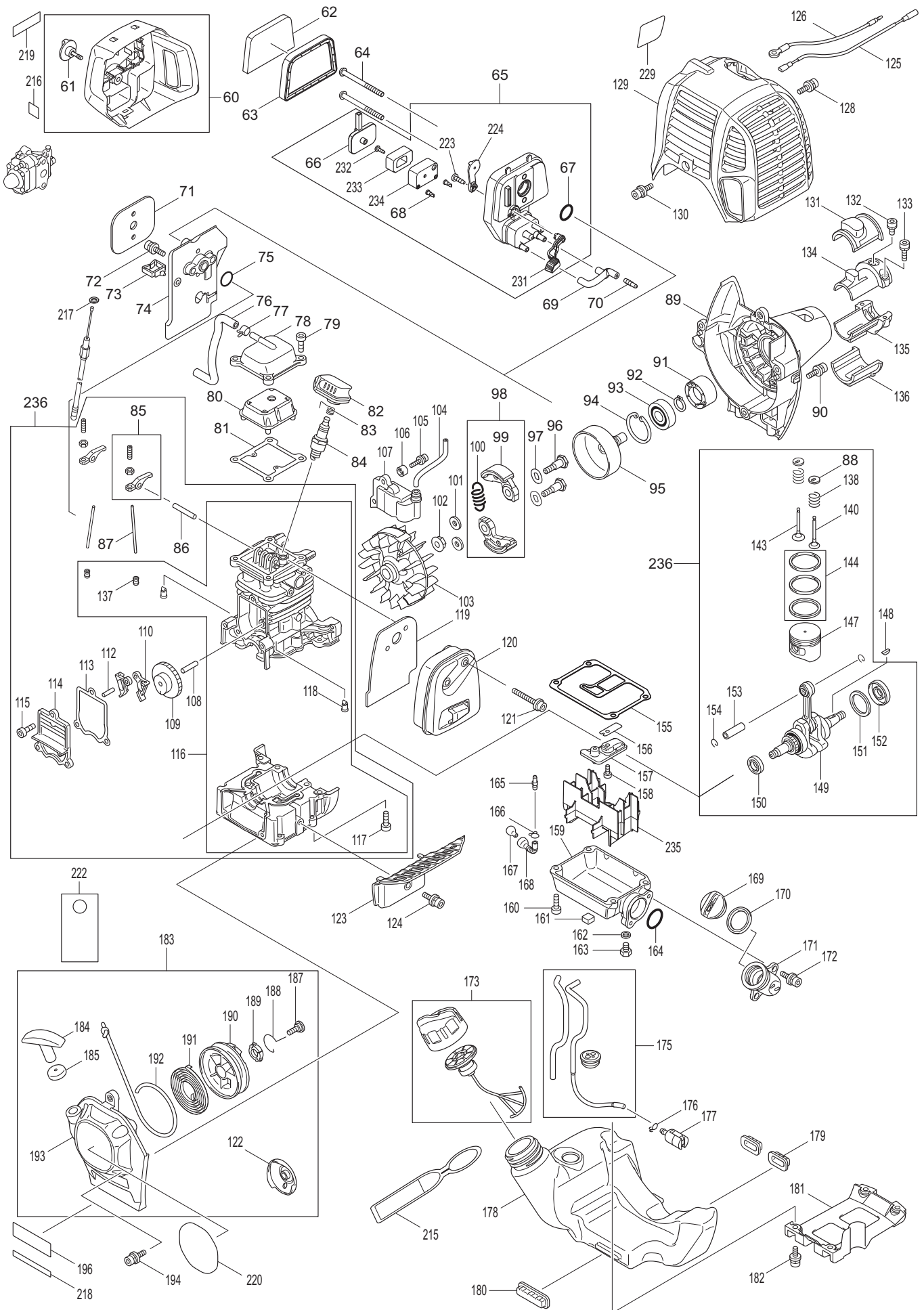

Seite / Page	Pos.	PE-254.4	Teil-Nr. Part No. No. de pièce No. de pieza	Hinweise Notes Renseign. Nota	Bezeichnung	Spezifikation Specification	Description	Désignation	Denominación
3	60	1	381 126 202		LUFTFILTERDECKEL KPL.		AIR CLEANER COVER ASSY.	COUVERCLE DE FILTRE A AIR CPL.	CUBIERTA DEL FILTRO DE AIRE CPL.
3	61	1	374 265 791		FLÜGELSCHRAUBE	M4	THUMB SCREW	VIS À OREILLES	TORNILLO DE MARIPOSA
3	62	1	367 443 171		LUFTFILTER		ELEMENT AIR CLEANER	FILTRE À AIR	FILTRO DE AIRE
3	63	1	367 443 169		LUFTFILTER		ELEMENT AIR CLEANER	FILTRE À AIR	FILTRO DE AIRE
3	64	2	367 266 618		SCHRAUBE	M5X60	H.S.BUTTON HEAD BOLT	VIS	TORNILLO
3	65	1	381 126 198		LUFTFILTERBODEN KPL.		AIR CLEANER PLATE ASS'Y	PLAQUE DE FILTRE A AIR CPL.	GRUPO DE LA PLANCHA DEL FILTRO
3	66	1	381 162 346		ÖLSEPARATOR		SEPARATOR PLATE	SÉPARATEUR D'HUILE	SEPARADOR DEL ACEITE
3	67	1	367 213 540		O-RING	15	O RING	ANNEAU TORIQUE	ANILLO OBTURADOR
3	68	2	367 424 316		RÜCKSCHLAGVENTIL		CHECK VALVE	SOUPAPE DE RETENU	VÁLVULA ANTIRRETORNO
3	69	1	381 422 099		SCHLAUCH		PIPE	TUYAU	TUBO
3	70	1	367 325 665		ANSCHLUßSTÜCK		JOINT PIPE	RACCORD	RACOR
3	71	1	367 442 153		DICHTUNG		CARBURETOR GASKET	JOINT	JUNTA
3	72	2	381 266 787		SCHRAUBE	M5X18 WR	H.S.H.BOLT	VIS	TORNILLO
3	73	1	367 451 825		KLAMMER		CLAMP	CRAMPON	GRAPA
3	74	1	367 451 729		ZWISCHENFLANSCH		INSULATOR	BRIDE INTERMEDIAIRE	BRIDA INTERMEDIA
3	75	1	367 213 547		O-RING	12	O-RING	ANNEAU TORIQUE	ANILLO OBTURADOR
3	76	1	381 422 109		ENTLÜFTUNGSSCHLAUCH	155mm	BREATHER PIPE	TUYAU DE PURGE	TUBO DE PURGA
3	77	1	367 345 918		SCHLAUCHKLEMME		HOSE CLAMP	COLLIER	ABRAZADERA
3	78	1	367 318 745		ABDECKUNG FÜR KIPPHEBEL, AUSSEN		ROCKER COVER OUTER	CAPOT POUR CULBUTEUR, EXT.	TAPA DE BALANCINES, EXT.
3	79	4	367 922 222		SCHRAUBE	M5X16	HEX. SOCKET HEAD BOLT	VIS HEXAGONAL	TORNILLO HEXAGONAL
3	80	1	381 453 860		ABDECKUNG FÜR KIPPHEBEL, INNEN		ROCKER COVER INNER	CAPOT POUR CULBUTEUR, INT.	TAPA DE BALANCINES, INT.
3	81	1	367 162 304		DICHTUNG, ABDECKUNG F.KIPPHEBEL		ROCKER COVER GASKET	JOINT, CAPOT POUR CULBUTEUR	JUNTA, TAPA DE BALANCINES CPL
3	82	1	374 424 302		STECKERKAPPE		PLUG CAP	CAPUCHON DE FICHE	TAPA DEL ENCHUFE
3	83	1	367 324 891		STECKERKAPPENFEDER		PLUG CAP SPRING	RESSORT CAPUCHON DE FICHE	MUELLE TAPA DEL ENCHUFE
3	84	1	367 168 534		ZÜNDKERZE	NGK CMR4A	SPARK PLUG	BOUGIE	BUJÍA
3	85	2	367 125 554		KIPPHEBEL KPL.		ROCKER ARM ASS'Y	CULBUTEUR CPL.	GRUPO DEL BALANCÍN CPL.
3	86	1	367 256 200		STIFT	5	PIN	GOUPILLE	PASADOR
3	87	2	367 256 865		STÖSSELSTANGE		ROD	TIGE-POUSSOIR	BARRA DE EMPUJADOR
3	88	2	367 325 668		FEDERTELLER		SPRING RETAINER	CUVETTE DE RESSORT	CAJA DE RESORTE
3	89	1	367 451 735		KUPPLUNGSGEHÄUSE		CLUTCH CASE	CARTER D' EMBAYAGE	CÁRTER DE EMBAGUE
3	90	3	367 922 228		SCHRAUBE	5X18	H.S.H.BOLT WITH WR	VIS	TORNILLO
3	91	1	367 450 569		DISTANZRING		SPACER	BAGUE D'ECARTEMENT	ANILLO DISTANCIADOR
3	92	1	660 961 052		SICHERUNGSRING	S-12	RETAINING RING	CIRCLIP	ANILLO SEGURIDAD
3	93	1	367 210 111		KUGELLAGER	6201DDU / 6201LLU	BALL BEARING	ROULEMENT À BILLES	RODAMIENTO DE BOLAS
3	94	1	367 962 151		SICHERUNGSRING	R-32	RETAINING RING	CIRCLIP	ANILLO SEGURIDAD

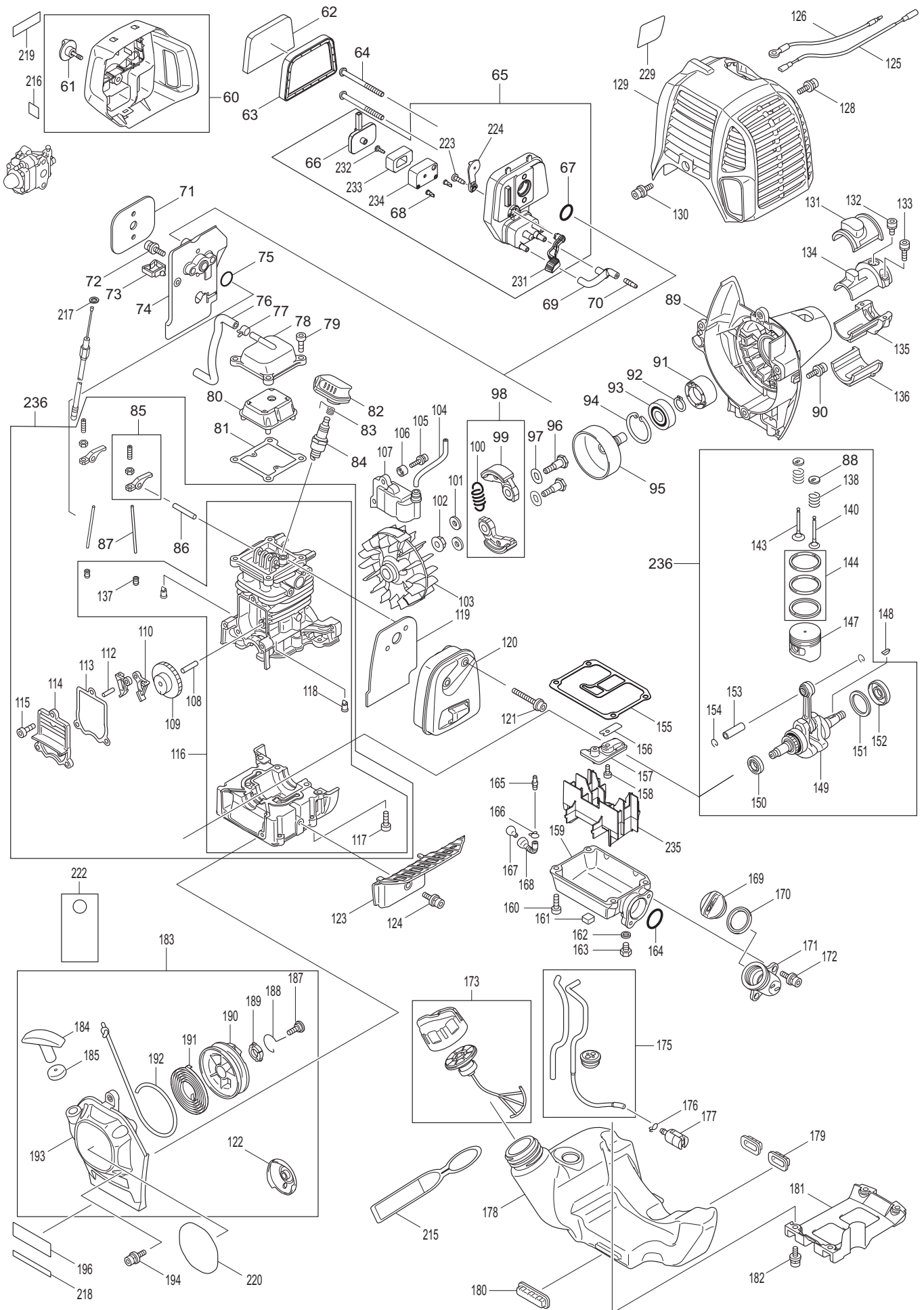

Seite / Page	Pos.	Teil-Nr. Part No. No. de pièce No. de pieza	Hinweise Notes Renseign. Nota	Bezeichnung	Spezifikation Specification	Description	Désignation	Denominación
3	95	1 367 168 809		KUPPLUNGSTROMMEL		CLUTCH DRUM	TAMBOUR	TAMBOR
3	96	2 367 266 864		SCHRAUBE	M6X25	SHOULDER HEX. BOLT	VIS HEXAGONAL	TORNILLO HEXAGONAL
3	97	2 367 267 817		SCHEIBE	8	WASHER	RONDELLE	ARANDELA
3	98	1 381 126 135		KUPPLUNG KPL.		CLUTCH ASSY.	EMBRAYAGE CPL.	EMBRAGUE CPL.
3	99	2 367 168 498		FLIEHGEWICHT		CLUTCH SHOE	MASSELOTTE	PESO CENTRIFUGA
3	100	1 381 231 881		ZUGFEDER	7	TENSION SPRING	RESSORT DE TRACTION	MUELLE DE TRACCIÓN
3	101	2 367 267 812		SCHEIBE	6	WASHER	RONDELLE	ARANDELA
3	102	1 374 109 107		BUNDMUTTER		FLANGE NUT	ECROU	TUERCA
3	103	1 367 318 569		POLRAD		FLYWHEEL	ROUE POLAIRE	VOLANTE ENCENDIDO
3	104	1 367 444 021		SCHLAUCH		TUBE	GAINÉ	TUBO
3	105	2 367 266 602		6KT-SCHRAUBE	M4X20	HEX. SOCKET HEAD BOLT	VIS HEXAGONAL	TORNILLO HEXAGONAL
3	106	2 367 452 049		DISTANZRING		SPACER	BAGUE D'ECARTEMENT	ANILLO DISTANCIADOR
3	107	1 367 168 559		ZÜNDANKER		IGNITION COIL	INDUIT	FIJ. DEL INDUCIDO
3	108	1 367 268 238		STIFT	5	PIN	GOUPILLE	PASADOR
3	109	1 367 125 552		NOCKENRAD		CAM GEAR ASS'Y	PIGNON DE DISTRIBUTION	GRUPO DEL ÁRBOL DE LEVAS
3	110	2 367 313 169		NOCKENHEBEL		CAM LIFTER	LEVIER A CAMES	LEVAS
3	112	1 367 268 239		STIFT	4	PIN	GOUPILLE	PASADOR
3	113	1 367 162 274		DICHTUNG		CAM GEAR COVER GASKET	JOINT	JUNTA
3	114	1 367 318 443		ABDECKUNG F.NOCKENRAD		CAMGEAR COVER	CAPOT	TAPA D. PIÑÓN D. ÁRB. DE LEV.
3	115	3 367 922 222		SCHRAUBE	M5X16	HEX. SOCKET HEAD BOLT	VIS HEXAGONAL	TORNILLO HEXAGONAL
3	116	1 367 135 478		ZYLINDERBLOCK SATZ		CYLINDER BLOCK SET	BLOC DE CYLINDRES	BLOQUE DE CILINDROS
3	117	6 367 922 222		SCHRAUBE	M5X16	HEX. SOCKET HEAD BOLT	VIS HEXAGONAL	TORNILLO HEXAGONAL
3	118	2 367 424 201		RÜCKSCHLAGVENTIL		CHECK VALVE	SOUPAPE DE RETENU	VÁLVULA ANTIRRETORNO
3	119	1 367 346 331		DICHTUNG SCHALLDÄMPFER		MUFFLER GASKET	JOINT DE POT D'ÉCHAPPEMENT	JUNTA DEL SILENCIADOR
3	120	1 367 168 554		SCHALLDÄMPFER		EXHAUST MUFFLER	POT D'ÉCHAPPEMENT	SILENCIADOR
3	121	2 367 266 440		SCHRAUBE	M5X40	HEX. SOCKET HEAD BOLT	VIS HEXAGONAL	TORNILLO HEXAGONAL
3	122	1 367 168 483		STARTERRAD		PULLEY STARTER	ROUE DÉMARREUR	RUEDA DE ARRANQUE
3	123	1 367 451 731		VERBRENNUNGSSCHUTZ		MUFFLER PLATE	PROTECTION DE COMBUSTION	PROTECCIÓN CONTRA COMBUSTIÓN
3	124	1 367 922 218		SCHRAUBE	M5X14	H.S.H.BOLT WITH WR	VIS	TORNILLO
3	125	1 367 638 707		KABEL		LEAD UNIT	CÂBLE	CABLE
3	126	1 367 638 708		KABEL		LEAD UNIT	CÂBLE	CABLE
3	128	1 367 922 218		SCHRAUBE	M5X14	H.S.H.BOLT WITH WR	VIS	TORNILLO
3	129	1 367 453 569		ZYLINDERHAUBE		CYLINDER COVER	CAPOT DE CYLINDRE	TAPA PARA CILINDRO
3	130	1 367 922 218		SCHRAUBE	M5X14	H.S.H.BOLT WITH WR	VIS	TORNILLO
3	131	1 374 424 082		GUMMIDÄMPFER		VIBRATION DAMPER	AMORTISSEUR DE VIBRATIONS	AMORTIGUADOR DE VIBRACIONES
3	132	1 367 922 211		SCHRAUBE	M5X12	HEX. SOCKET HEAD BOLT	VIS HEXAGONAL	TORNILLO HEXAGONAL
3	133	2 367 922 226		SCHRAUBE	M5X18	HEX. SOCKET HEAD BOLT	VIS HEXAGONAL	TORNILLO HEXAGONAL
3	134	1 374 318 249		KLEMMSCHALE		PIPE BRACKET	COLLIER D'ATTACHE	TUBO PARTIDO

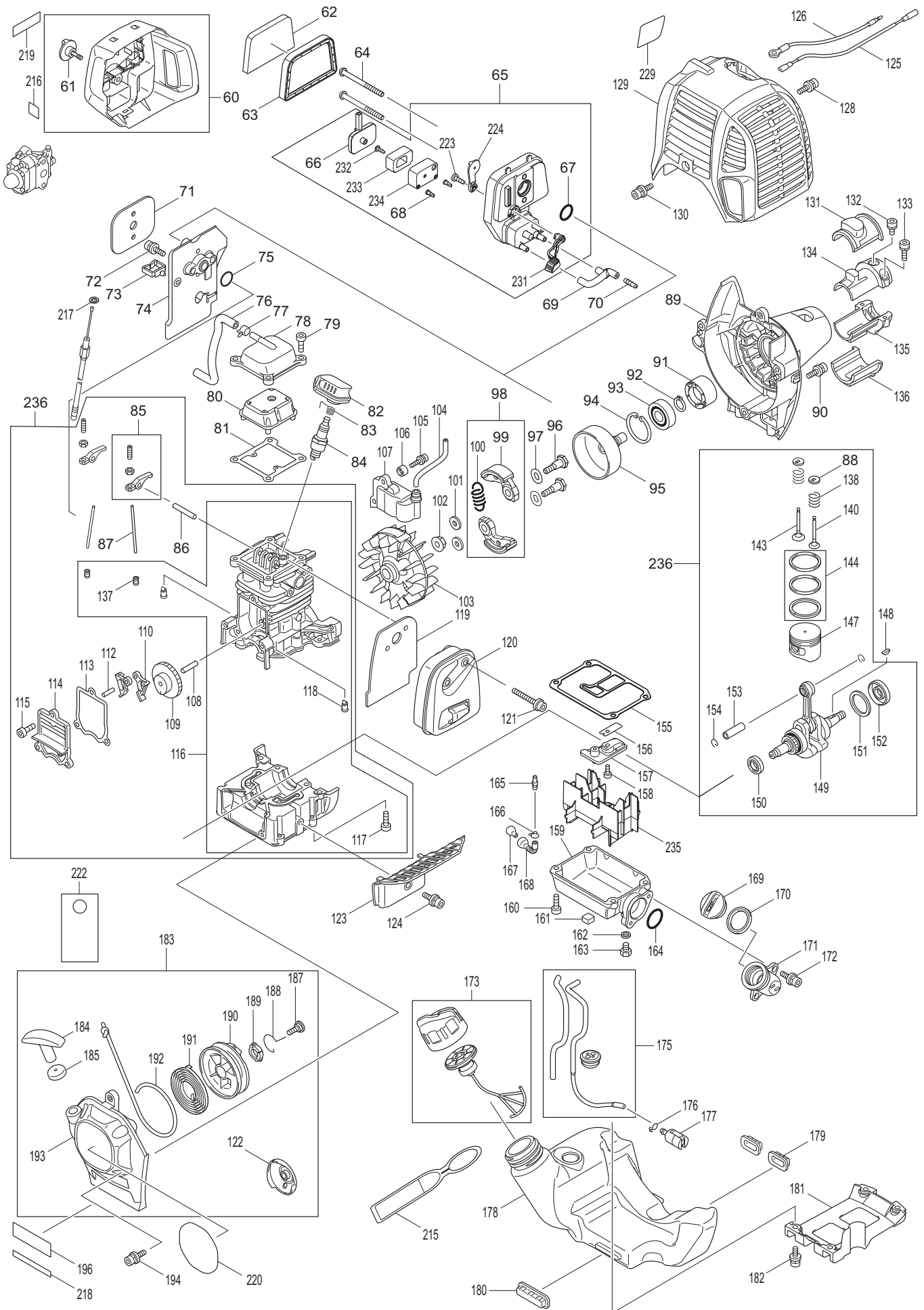

Seite / Page	Pos.	Teil-Nr. Part No. No. de pièce No. de pieza	Hinweise Notes Renseign. Nota	Bezeichnung	Spezifikation Specification	Description	Désignation	Denominación
3	135	1 374 318 250		KLEMMSCHALE		PIPE BRACKET	COLLIER D'ATTACHE	TUBO PARTIDO
3	136	1 374 424 083		GUMMIDÄMPFER		VIBRATION DAMPER	AMORTISSEUR DE VIBRATIONS	AMORTIGUADOR DE VIBRACIONES
3	137	2 367 424 200		DISTANZBUCHSE		SPACER	DOUILLE	CASQUILLO
3	138	2 367 234 108		DRUCKFEDER	9	COMPRESSION SPRING	RESSORT DE PRESSION	MUELLE DE COMPRESIÓN
3	140	1 367 325 669		AUSLASSVENTIL		EXHAUST VALVE	SOUPAPE D'EMISSION	VÁLVULA DE ESCAPE
3	143	1 367 325 670		EINLASSVENTIL		INTAKE VALVE	VALVE D'ADMISSION	VÁLVULA DE ADMISIÓN
3	144	1 367 195 145		KOLBENRING-SATZ		PISTON RING SET	JEU DE SEGMENTS DE PISTON	JUEGO DE SEGMENTOS DEL PISTÓN
3	147	1 367 318 441		KOLBEN		PISTON	PISTON	PISTÓN
3	148	1 367 254 040		SCHEIBENFEDER	3	WOODRUFF KEY	CLAVETTE	CHAVETA
3	149	1 367 126 359		KURBELWELLE KPL.		CRANKSHAFT ASS'Y	VILEBREQUIN CPL.	CIGÜEÑAL CPL.
3	150	1 367 213 148		ÖLDICHTUNG	10	OIL SEAL	JOINT ÉTANCHE À L'HUILE	RETÉN DE ACEITE
3	151	1 367 267 400		FLACHSCHEIBE	23	FLAT WASHER	RONDELLE PLATE	ARANDELA
3	152	1 367 213 147		ÖLDICHTUNG	12	OIL SEAL	JOINT ÉTANCHE À L'HUILE	RETÉN DE ACEITE
3	153	1 367 257 781		KOLBENBOLZEN		PISTON PIN	AXE DE PISTON	BULÓN DEL PISTÓN
3	154	2 367 233 976		SPRENGRING		CLIP	ANNEAU RESSORT	ANILLO ELÁSTICO
3	155	1 381 162 345		DICHTUNG		OIL CASE GASKET	JOINT	JUNTA
3	156	1 367 346 083		EINLASSMEMBRAN (REEDVALVE)		LEAD VALVE	MEMBRANE D'ADMISSION	VÁLVULA CON MEMBRANA DE ADMISIÓN
3	157	1 381 318 910		STOPPER FÜR REEDVALVE		RETAINER PLATE	FILTRE EN FEUTRE	FILTRO DE FIELTRO
3	158	1 367 922 112		6KT-SCHRAUBE	M4X10	HEX. SOCKET HEAD BOLT	VIS HEXAGONAL	TORNILLO HEXAGONAL
3	159	1 367 318 588		ÖLWANNE		OIL CASE	CUVETTE A HUILE	CÁRTER DE ACEITE
3	160	4 367 922 222		SCHRAUBE	M5X16	HEX. SOCKET HEAD BOLT	VIS HEXAGONAL	TORNILLO HEXAGONAL
3	161	1 367 424 344		DÄMPFER		DAMPER	AMORTISSEUR	AMORTIGUADOR
3	162	1 367 346 305		DICHTUNG		GASKET	JOINT	JUNTA
3	163	1 367 266 611		6KT-SCHRAUBE	M6X8	HEXAGON BOLT	VIS À SIX PANS	TORNILLO HEXAGONAL
3	164	1 367 213 548		O-RING	20	O-RING	ANNEAU TORIQUE	ANILLO OBTURADOR
3	165	1 367 325 665		ANSCHLUßSTÜCK		JOINT PIPE	RACCORD	RACOR
3	166	1 367 282 020		SCHLAUCHKLEMME		HOSE CLAMP	COLLIER	ABRAZADERA
3	167	1 367 325 666		GEWICHT F.ÖLLEITUNG		OIL WEIGHT	POIDS POUR TUYAU D'HUILE	PESA PARA EL TUBO DEL ACEITE
3	168	1 367 424 301		ÖLLEITUNG		OIL TUBE	TUYAU DE L'HUILE	TUBERÍA DE ACEITE
3	169	1 388 650 150		ÖLDECKEL		OIL CAP	BOUCHON	TAPA
3	170	1 388 322 999		DICHTUNG		GASKET	JOINT	JUNTA
3	171	1 367 452 048		EINFÜLLSTUTZEN		OIL PIPE	TUBULURE DE REMPLISSAGE	TUBO DE LLENADO
3	172	2 367 922 218		SCHRAUBE	M5X14	H.S.H.BOLT WITH WR	VIS	TORNILLO
3	173	1 367 125 728		KRAFTSTOFFTANKD ECKEL KPL.		FUEL TANK CAP ASSEMBLY	BOUCHON RESERVOIR CPL., CARBURANT	TORNILLO DE CIERRE CPL., COMBUSTIBLE
3	175	1 367 168 755		SCHLAUCH KPL.		TUBE COMPLETE	TUBE CPL.	TUBO CPL.
3	176	1 367 282 020		SCHLAUCHKLEMME		HOSE CLAMP	COLLIER	ABRAZADERA
3	177	1 367 163 518		BENZINFILTER		GASOLIN FILTER	FILTRE D'ESSENCE	FILTRO DE GASOLINA
3	178	1 367 451 736		KRAFTSTOFFTANK		FUEL TANK	RESERVOIR D'ESSENCE	DÉPÔSITO DE COMBUSTIBLE
3	179	2 374 424 080		GUMMIDÄMPFER		VIBRATION DAMPER	AMORTISSEUR DE VIBRATIONS	AMORTIGUADOR DE VIBRACIONES
3	180	1 374 424 081		GUMMIDÄMPFER		VIBRATION DAMPER	AMORTISSEUR DE VIBRATIONS	AMORTIGUADOR DE VIBRACIONES

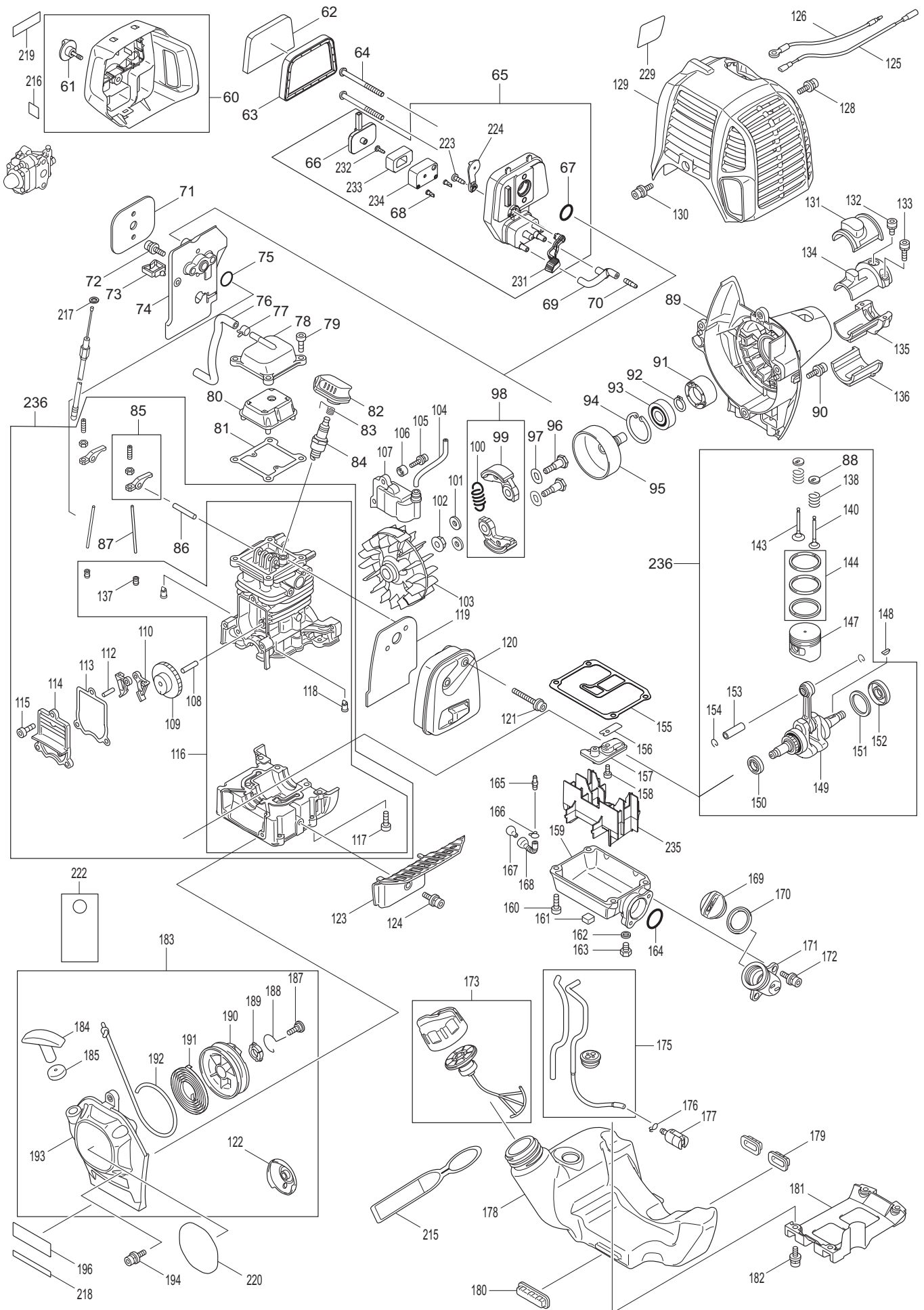

PE-254.4

3

Motor
Engine
Moteur
Motor

A member of the *Makita* Group

Seite / Page	Pos.	PE-254.4	Teil-Nr. Part No. No. de pièce No. de pieza	Hinweise Notes Renseign. Nota	Bezeichnung	Spezifikation Specification	Description	Désignation	Denominación
3	181	1	367 451 737		SCHUTZBÜGEL FÜR TANK		TANK GUARD	BRIDE DE PROTECTION	BRIDA DEL DEPÓSITO
3	182	4	367 922 218		SCHRAUBE	M5X14	H.S.H.BOLT WITH WR	VIS	TORNILLO
3	183	1	367 195 308		ANWERFVORRICHTU NG KPL.		RECOIL STARTER SET	DEPOSITE DE DEMARRAGE CPL.	DEPOSITO DE ARRANQUE CPL.
3	184	1	367 424 319		ANWERFGRIF		STARTER KNOB	POIGNÉE DE LANCLEMENT	TIRADOR DE ARRANQUE
3	185	1	367 424 359		DÄMPFER		DAMPER	AMORTISSEUR	AMORTIGUADOR
3	187	1	367 266 585		BLECHSCHRAUBE	5X12	TAPPING SCREW	VIS TARAUEUSE	TORNILLO DE ROSCA CORTANTE
3	188	1	367 325 923		MITNEHMERBÜGEL		SWING ARM	ETRIER D'ENTRAINEMENT	BRAZO OSCILANTE
3	189	1	367 451 938		AUFNAHME F. MITNEHMERBÜGE L		COLLAR	LOGEMENT POU ETRIER	ANILLO DE RETENCIÓN
3	190	1	367 451 937		SEILTROMMEL		REEL	TAMBOUR DE CÂBLE	TAMBOUR PARA CORDÓN
3	191	1	367 232 258		SPIRALFEDER		SPIRAL SPRING	RESSORT DE RAPPEL	RESORTE RETENCION
3	192	1	367 444 023		ANWERFSEIL		STARTER ROPE	CORDE DE LANCEUR	CUERDA DE ARRANQUE
3	193	1	367 451 733		ANWERFGEHÄUSE		STARTER CASE	BOÎTIER DISPOS. DE DÉMARRAGE	CAJA DISPOS. DE ARRANQUE
3	194	4	367 922 223		SCHRAUBE	M5X16	H.S.H.BOLT WITH WR	VIS	TORNILLO
3	196	1	367 891 121		SCHILD	DOLMAR LOGO	LABEL	PLAQUE	CALCOMANIA
3	215	1	367 810 455		HINWEISSCHILD F. KRAFTSTOFFART		CAUTION PLATE	PLAQUE POUR TYPE DE CARBURANT	ETIQUETA DE INDICACIÓN
3	216	1	381 800 073		HINWEISSCHILD		INDICATION LABEL	PLAQUE	ETIQUETA DE INDICACIÓN
3	217	1	367 941 152		FLACHSCHEIBE	6	FLAT WASHER	RONDELLE PLATE	ARANDELA
3	218	1			SCHILD	SERIAL NO.	LABEL	PLAQUE	CALCOMANIA
3	220	1	367 803 025		SCHILD	PE-254.4	MODEL LABEL	PLAQUE	CALCOMANIA
3	222	1	367 819 430		SICHERHEITSANHÄN GER	DE, FR	CAUTION TAG	PLAQUE	CALCOMANIA
3	223	1	367 266 427		SCHNEIDSCHRAUBE	4X12	TAPPING SCREW	VIS TARAUEUSE	TORNILLO DE ROSCA CORTANTE
3	224	1	367 452 219		CHOKEKLAPPE		CHOKE PLATE	CLAPET DE STARTER	TAPA DEL CHOKE
3	229	1	381 801 053		ABGASAUFKLEBER		GAS EMISSION APPROVAL LABEL	PLAQUE, GAZ D'ÉCHAPPEMENT	CALCOMANIA, GAS DE ESCAPE
3	231	1	367 452 220		CHOKEHEBEL		CHOKE LEVER	LEVIER DE STARTER	PALANCA ESTRANGULADOR DE AIRE
3	232	1	320 266 007		GEWINDESCHNEIDS CHRAUBE	3X10	TAPPING SCREW BIND	VIS TARAUEUSE	TORNILLO DE ROSCA CORTANTE
3	233	1	381 352 020		NETZGEWEBE		SEPARATOR MESH	TISSU	ENTRESIJO
3	234	1	381 453 865		SEPERATORGEHÄU SE		SEPARATOR CASE	CARTER	CÁRTER
3	235	1	381 453 862		ÖLWANNENEINSATZ		OIL CASE PLATE	INSERT POUR CUVETTE A HUILE	INSERTO PARA CÁRTER DE ACEITE
3	236	1	367 135 599		SHORT BLOCK	25.4CC INC. 85-88,108-110,112 -118, 137,138,140,143,1 44,14	SHORT BLOCK ASSY.	SHORT BLOCK	SHORT BLOCK

197

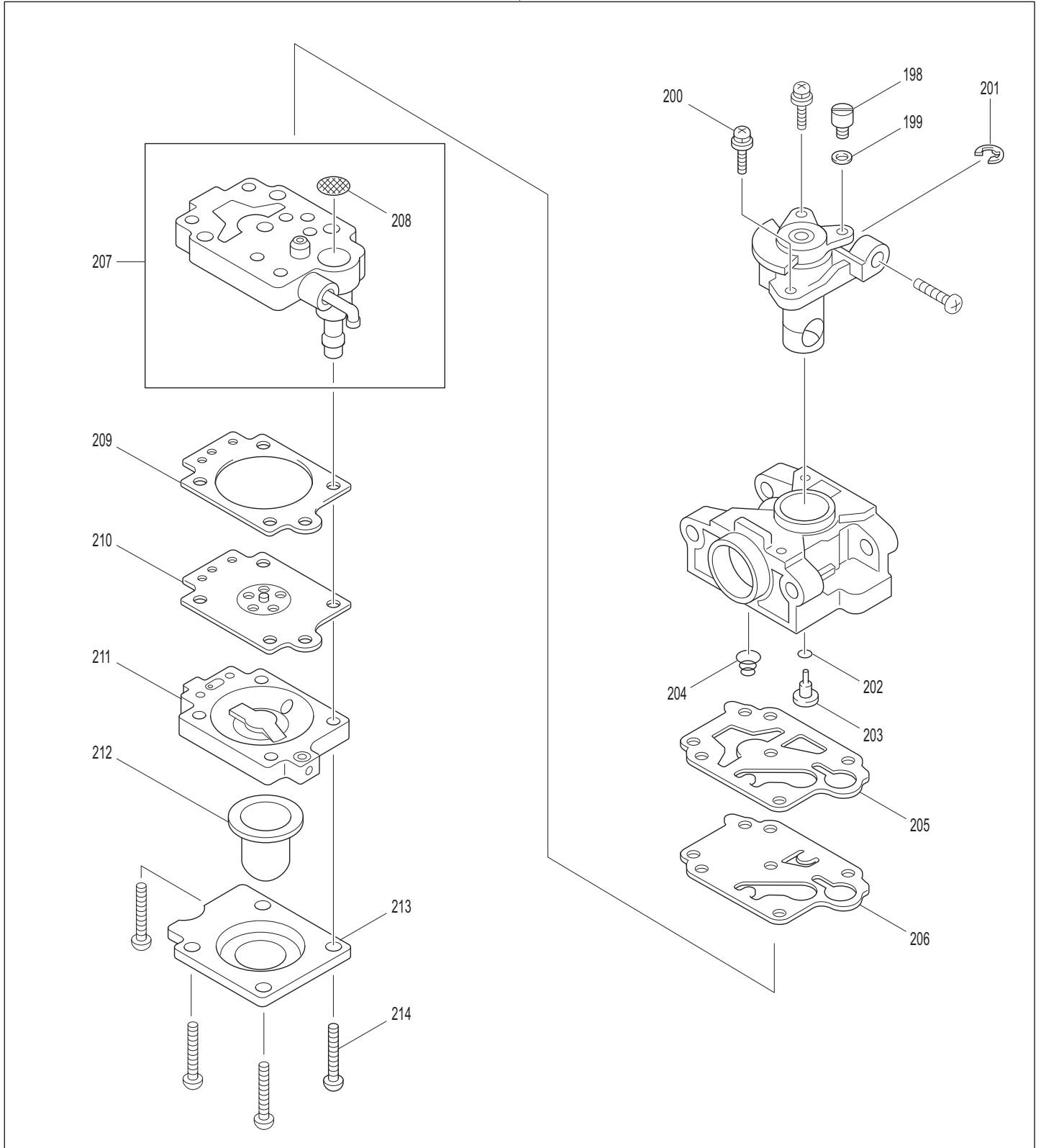

PE-254.4

4

Vergaser
Carburetor
Carburateur
Carburador**DOLMAR**
A member of the *Makita* Group

Seite / Page	Pos.	PE-254.4	Teil-Nr. Part No. No. de pièce No. de pieza	Hinweise Notes Renseign. Nota	Bezeichnung	Spezifikation Specification	Description	Désignation	Denominación
4	197	1	381 168 762		VERGASER	WYL287A	CARBURETOR	CARBURATEUR	CARBURADOR
4	198	1	367 325 922		NOCKEN		SWIVEL	CAME	LEVA
4	199	1	367 413 140		SCHEIBE		WASHER	RONDELLE	ARANDELA
4	200	2	367 266 581		FLACHKOPFSCHRAUBE	M3X8	PAN HEAD SCREW	VIS À TÊTE CYLINDRIQUE	TORNILLO DE CABEZA PLANA
4	201	1	367 257 964		SICHERUNGSRING	E-3	STOP RING	CIRCLIP	ANILLO SEGURIDAD
4	202	1	367 213 538		O-RING	2	O RING	ANNEAU TORIQUE	ANILLO OBTURADOR
4	203	1	367 325 985		DÜSE		JET	BUSE	CHICLÉ
4	204	1	367 234 183		DRUCKFEDER	5-9	CONICAL COMPRESSION SPRING	RESSORT DE PRESSION	MUELLE DE COMPRESIÓN
4	205	1	367 442 155		PUMPENDICHTUNG		PUMP GASKET	JOINT	JUNTA
4	206	1	367 168 575		PUMPENMEMBRANE		PUMP DIAPHRAGM	MEMBRANE DE POMPE	MEMBRANAS DE LA BOMBA
4	207	1	381 141 737		PUMPENKÖRPER		PUMP BODY	POMPE	BOMBA
4	208	1	367 352 021		SIEB		INLET SCREEN	TAMIS	TAMIZ
4	209	1	367 442 154		DICHTUNG		METERING DIAPHRAGM GASKET	JOINT	JUNTA
4	210	1	367 168 620		STEUERMEMBRAN		METERING DIAPHRAGM	MEMBRANE DE COMMANDE	MEMBRANAS DE MANDO
4	211	1	367 140 438		PUMPENABDECKUNG		AIR PURGE BODY ASSY	COUVERCLE	CUBIERTA
4	212	1	367 424 314		PRIMER PUMPE		PRIMER PUMP	POMPE PRIMER	BOMBA PRIMER
4	213	1	367 346 270		PRIMERDECKEL		PRIMER PUMP COVER	COUVERCLE DE POMPE PRIMER	TAPA DEL PRIMARIO
4	214	4	367 266 582		BLECHSCHRAUBE	3X24	TAPPING SCREW	VIS TARAUDEUSE	TORNILLO DE ROSCA CORTANTE

- 1** Rasenkantenschneider, Zubehör
 Edger, accessory
 Dresse-bordures, accessoires
 Rebordeadora, accesorios
- 2** Bedienungshandgriff
 Control lever
 Levier de réglage
 Botón de mando
- 3** Motor
 Engine
 Moteur
 Motor
- 4** Vergaser
 Carburetor
 Carburateur
 Carburador

	Zeichenerklärung	Key to symbols
=> 1999999 2000000 => 2003.04 => TI 2003/07 Acc. = { m Corr.	Produktion bis Serien-Nr. Neues Teil ab Serien-Nr. Neues Teil ab Jahr / Monat Siehe Technische Information Jahr / Nr. Zubehör (nicht im Lieferumfang) Keine Serienausführung, jedoch verwendbar Beinhaltet Positions-Nr. Meterware Druckfehlerberichtigung	Production to serial number New part from serial number New part from Year / Month See Technical Information Year / No. Accessories (not included in the delivery inventory) No standard execution, may be used Contains item number Sold by the meter Error correction
	Änderungen vorbehalten	Specifications subject to change without notice
	Légende	Explicación de símbolos
=> 1999999 2000000 => 2003.04 => TI 2003/07 Acc. = { m Corr.	Production jusqu'à n° de série Nouvelle pièce à partir du n° de série Nouvelle pièce à partir de année / mois Voir information technique année / n° Accessoires (non compris dans la livraison) Aucune exécut. en série, cependant utilisable contient n° de numéro Au mètre Rectification d'erreurs	Producción hasta N° de serie Pieza nueva a partir de N° de serie Pieza nueva a partir de año / mes Véase inform. técnico año / N° Accesorios (no incluido en la extensión del suministro) No es de serie, pero sirve Contiene pos N° Por metro Fe de erratas
	Changements sans préavis	Mejoras constructivas sin previo aviso